

REVISIONS				
ECN	REV	DESCRIPTION	DATE	BY
1420	A	RELEASED FOR PRODUCTION	03/05	MWJ

ITEM NO.	PART NUMBER	DESCRIPTION	exploded view/QTY.
1	156001F	CORNER ROLLER HEAD, NON-LOGO	1
2	151006	STUD	4
3	154007	SWIVEL ASSEMBLY	1
4	150004F	SWIVEL COUPLING PIN	1
5	159023	NYLON WASHER	8
6	151011	INNER ROLLER	4
7	151005	OUTER ROLLER ASSEMBLY	4
8	150009	SWIVEL AXLE	1
9	059143	COTTER PIN	1
10	129061	E-CLIP	4
11	150003F	COUPLING	1
12	164348	CR HANDLE ASSY, SOLD	1
13	151042	HANDLE GRIP, BLACK, NO LOGO	1
14	159010	8-32 3/8 FILLISTER HEAD SCREW	1

	BY	DATE	CORNER ROLLER	
DRAWN	MWJ	03/05		
CHECKED				
ALL DIMENSIONS IN INCHES UNLESS OTHERWISE NOTED TOLERANCES UNLESS NOTED			 <b>an Axia Enterprise</b>	
.XX ± 0.010"      ANGULAR ±.5° .XXX ± 0.005"				
MATERIAL :			SIZE <b>B</b>	REV. <b>A</b>
			SCALE = 1:1	DWG. NO. 15TTE
			ASSEMBLY REF. NO.	SHEET 1 of 2

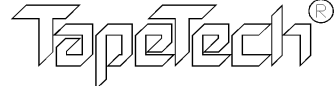
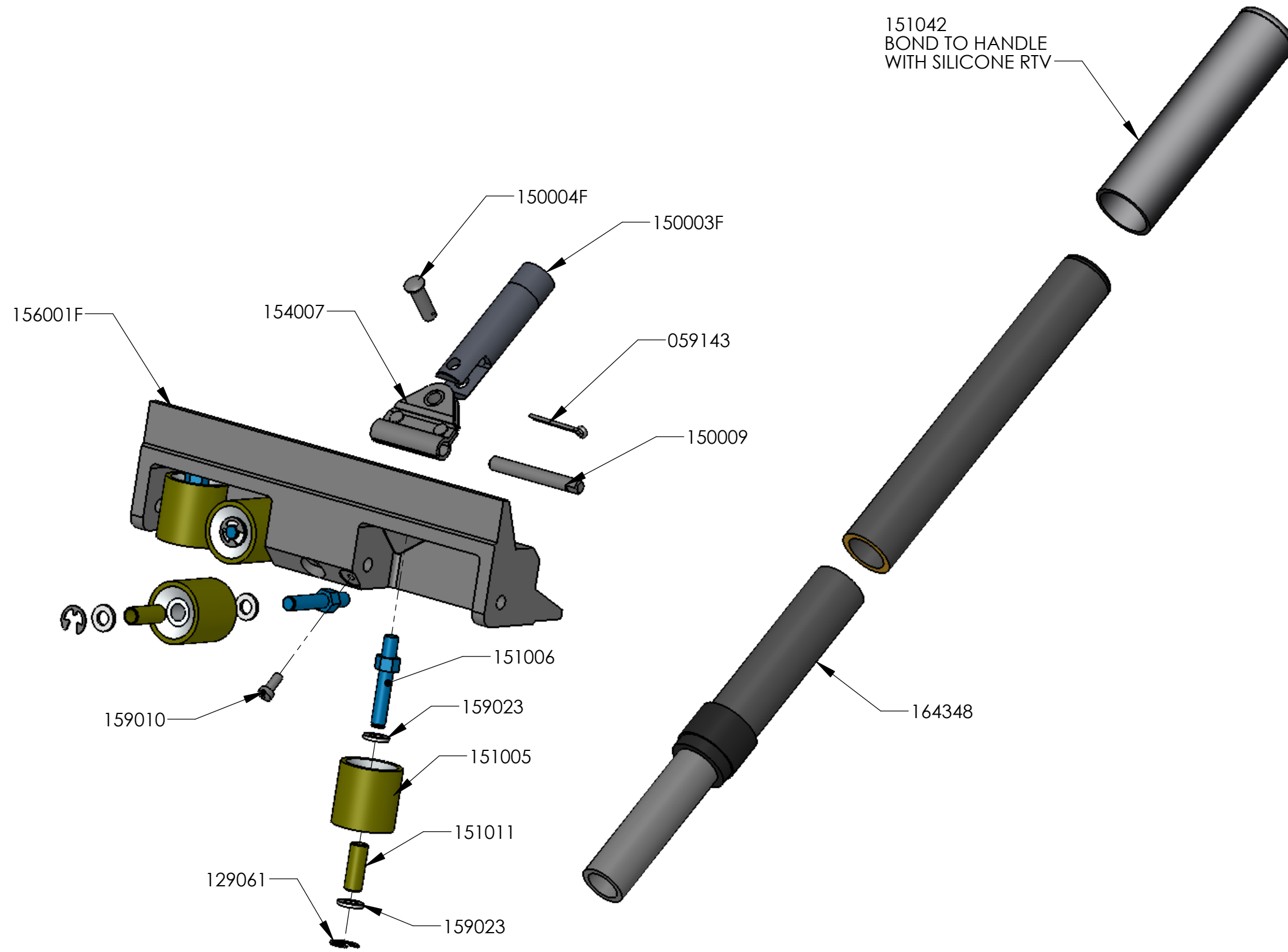
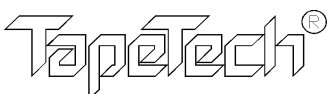

15TTE	CORNER ROLLER	
	 an <i>Axia</i> Enterprise	REV. A